

REVISIONS				
ECO	REV.	DESCRIPTION	DATE	INC.
	A	RELEASED	2/27/2004	

10" SOLATUBE INCANDESCENT LIGHT KIT HARD CEILING

NOTES:

1. DIMENSIONS IN BRACKETS ARE METRIC UNLESS OTHERWISE SPECIFIED.
2. 6" MINIMUM CLEARANCE SHOULD BE MAINTAINED FROM ALL SOLATUBE COMPONENTS AND OTHER PLENUM ELEMENTS.

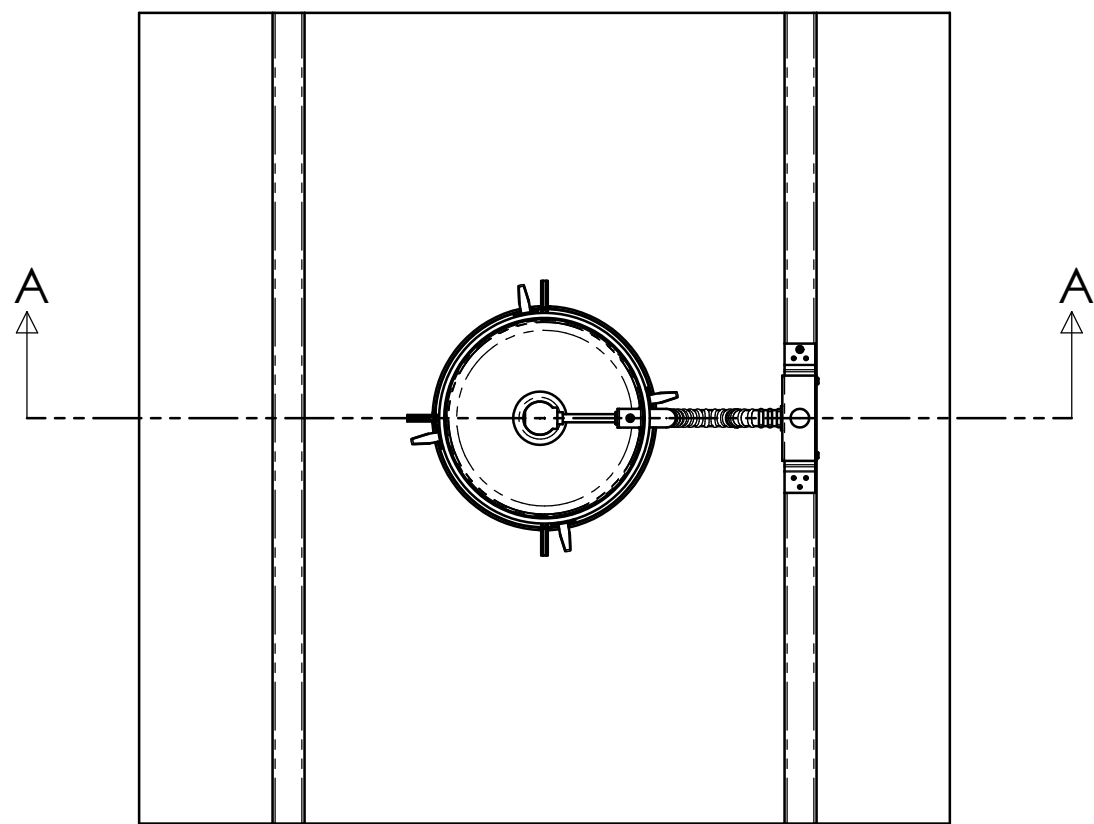
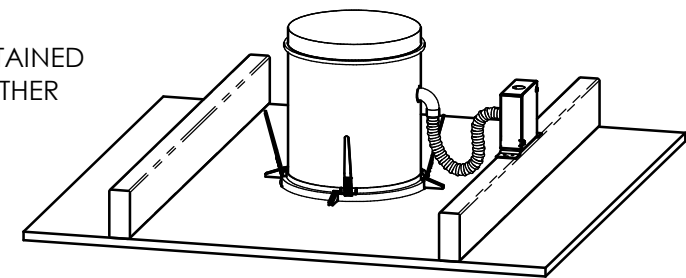

TOP VIEW
SCALE 1:1

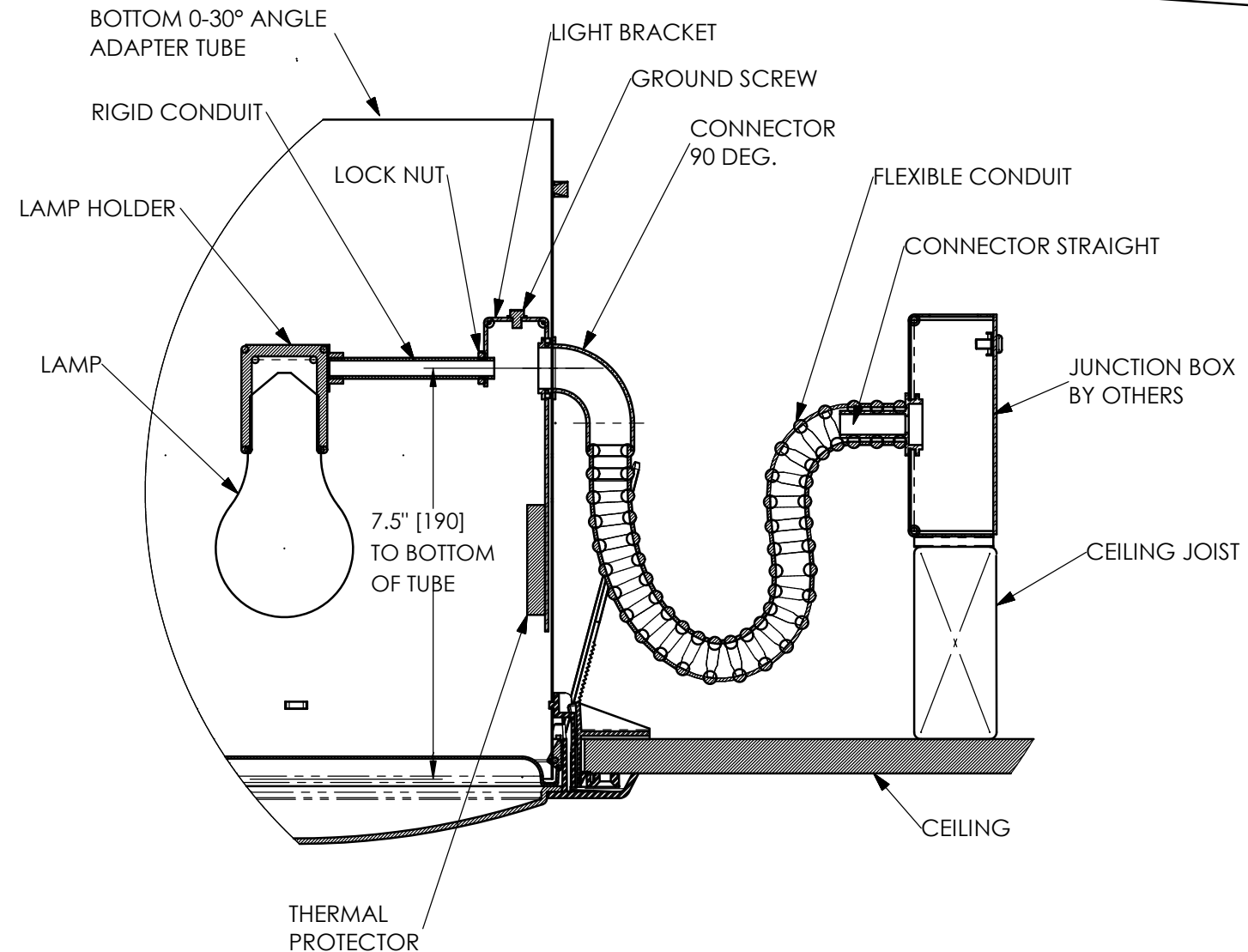

DETAIL B
SCALE 3:1

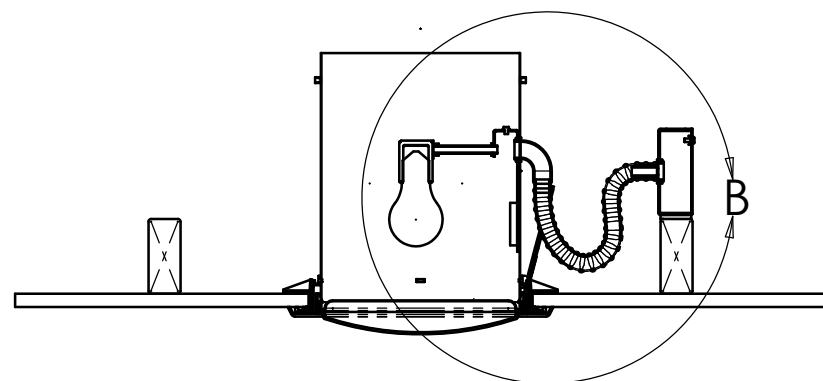

FULL SECTION A-A
SCALE 1:1

UNLESS OTHERWISE SPECIFIED:		SOLATUBE INTERNATIONAL, INC. COPYRIGHT 2002 WWW.SOLATUBE.COM			
DIMENSIONS ARE IN INCHES TOLERANCES: ANGULAR: $\pm 0.5^\circ$.X $\pm .1$.XX $\pm .02$ MATERIALS $\pm .005$		DRAWN BY STEVENS	DATE 2/23/04	TITLE: 10" SOLATUBE INCANDESCENT LIGHT KIT	
FINISH --		CHECKED BY --	DATE --	SIZE D	DWG. NO. 10-HC-INCAN
DO NOT SCALE DRAWING		APPROVED BY --	DATE --	SCALE: 1:1	REV A
				SHEET 1 OF 1	